

Evaporators and air coolers REBF, RBBF, RABF and RGBF

Series R_BF is consisting of evaporators and air coolers for fast cooling or freezing of meat, fish, ice cream and for ready meals for tunnels where are required high capacities in limited spaces.

This type of unit grants a perfect and fast cooling of product thanks special fans with high static pressure.

These units are available with different type of refrigerants:

- Dry expansion evaporators HFC
- Air coolers for no frost solutions
- Dry expansion evaporators CO₂
- Pump ammonia evaporators

Capacity range from 21 to 106 kW



Casing

The frame design provides high rigidity.

Casing manufactured from galvanized steel powder painted colour RAL 9002, corrosion resistant.

All rivets and bolts are in stainless steel AISI 304.

Heat exchanger

Heat exchanger is equipped with suspending tubes system that avoid the contact between tubes and frame and it provides full protection of the heat exchanger against vibrations and thermal expansions.

The coil is realized with copper pipes (rippled for REBF and RBBF to grant high efficiency and optimal evaporation, smooth for RGBF, diam. 16 mm and minimum thickness 0,3 mm) and aluminium fins. For ammonia evaporators RABF, pipes are in stainless steel AISI 304, diam. 16 mm and minimum thickness 0,7 mm.

Evaporators HFC: PS 30 bar and TS -40 / +120 °C, according to standards PED 2014/68/EU.

Evaporators CO₂: PS 33, 45 and 60 bar and TS -45 / +120 °C, according to standards PED 2014/68/EU.

Air coolers: PS 16 bar and TS -40 / +120 °C, according to standards PED 2014/68/EU.

Ammonia evaporators: PS 23 bar and TS -40 / +120 °C, according to standards PED 2014/68/EU.

Fans

High efficiency fans provide high performances with limited power consumption. They are complete of thermal protection, protection grid according to EN ISO 13857, dynamically and statically balanced and according to ErP directive.

AC and EC fans are available with diameter 500 and 630 mm with motors with external rotor, insulation class F, standard protection degree IP 54 (EN 60529).

Standard static available pressure is from 80 to 150 Pa.

Standards

The products are designed and manufactured according to following EU Directive:

- PED 2014/68/UE
- 2006/42/CE (Machinery Directive)
- 2014/35/UE (LVD Directive)
- 2014/30/UE (EMC Directive)

Options

- Fins spacing 4,0 – 6,0 – 8,0 – 10,0 – 12,0 mm
- Stainless steel pipes AISI 304 or AISI 316L
- Stainless steel fins AISI 304 or AISI 316L
- Epoxy coated aluminum fins
- Protective coating on coil
- Fins alloy AlMg
- Stainless steel grids AISI 304
- Insulated drip tray
- Electric, light electric, hot gas, hot glycol, water or combined
- defrost
- Fans ring heaters
- Drain outlet heater
- Switch of each for fans
- AC and EC fans wiring
- Stainless steel casing AISI 304 or AISI 316L

Code key

R	B	BF	050	2	D	6	HG	4	D
1	2	3	4	5	6	7	8	9	10

1. Refteco
2. Type of refrigerant (E = HFC, G = glycol, B = CO2, A = ammonia)
3. Blast Frezeer
4. Fan diameter (mm)
5. Number of fans
6. Size of coil (number of rows)
7. Fins spacing (mm)
8. Type of defrost (A = air, E = electric, EL = light electric W = water, HG = hot gas, GC = hot glycol)
9. Poles number of fans
10. Fans connection (D = triangle, Y = star)

Dimensions

Model	Dimensions (mm)			
	L	W	H	D
R_BF 0502	1450	834	1795	2"
R_BF 0504	2350	834	1795	2"
R_BF 0506	3250	834	1795	2"
R_BF 0508	4150	834	1795	2"
R_BF 05010	5050	834	1795	2"
R_BF 0632	1650	918	2275	2"
R_BF 0634	2750	918	2275	2"
R_BF 0636	3850	918	2275	2"
R_BF 0638	4950	918	2275	3"
R_BF 06310	6050	918	2275	3"

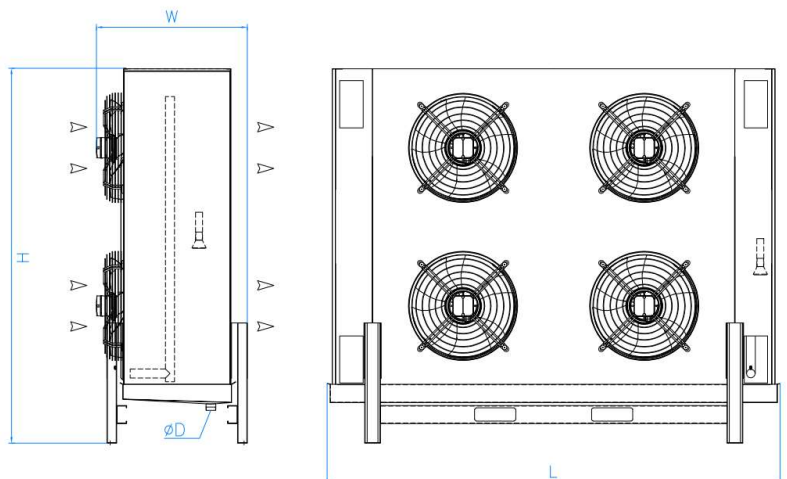

Warranty

Products are granted, against any construction defect, for 24 months from shipping date. Damage caused by normal wear, corrosion, faulty assembly or maintenance are excluded.